



The company was founded in 1987 by transforming the former CSA, which was a trading company dealing with pipes and valves for water networks, into a manufacturing company, through the research and realization of pillar fire hydrants. These were compliant with the UNI 9485 regulation, which was at the approval stage. Since then many other products have been added.

The history of our company is characterised by years of technical and commercial research, which have enabled us to offer a complete range of valves designed for controlling, regulating and protecting the pipelines under pressure in both waterworks and sewage lines as well as fire hydrants.

Our many industrial patents and innovative technical solutions, together with modern and attractive style of design, have made it possible to differentiate our products from those offered by competitors and have allowed us to become a point of reference in our sector.

Flexibility and reliability have been the key points of CSA's rapid growth over the last few years. We are perfectly aware that we are managing the world's most precious resource and, motivated by this responsibility and the commitment towards our customers, we have dedicated ourselves to constantly improving our products, placing them at the highest levels of quality.

Quality

In the manufacturing business today, quality is the fundamental requirement for achieving and maintaining a growing market share.

For this reason we have always aimed at developing a synergy between the various sectors of the company and thus ensuring:

- Quick and precise answers;
- Evaluation of data received and immediate response;
- Rigorous control of incoming and outgoing products.

Since 1998 CSA is certified according to regulation ISO 9001 by RINA (Italian Naval Registry) recently converted into ISO 9001/2008.





During the research and realisation of new products, CSA has always focused his efforts on:

- Listening to the customer's needs and finding the best solution both at the design and operational phases.
- Guiding our R&D department to develop ranges of modern, reliable and complementary products.
- Adopting production techniques that, even while complying with the severest quality standards, would allow us to reduce delivery times.
- Guaranteeing complete technical support for our customers and prompt after-sales assistance.

This philosophy characterizes us not only as a valve manufacturer but also as a reliable partner whom you can

always depend on for consulting and solutions.

The production cycle, aimed at the constant improvement of our products and complete customer satisfaction, ensures predetermined margins of tolerance by establishing production standards, which guarantee that the semi finished products reach the next production stage with the required specifications.

All our valves are made of ductile cast iron GJS 400-15 / 500-7 in absolute compliance with European standards, and are suitable for PN 25-40 bar.

The manufacturing process is carried out exclusively by means of numerically controlled lathes, mills, and horizontal machining units. Subsequent step-by-step controls are based on strict quality procedures. Painting, pre-treated by sand blasting grade SA 2.5, is carried out inside a fluidized bed containing epoxy powder, which guarantees maximum surface protection. All our products are tested under water pressure and certified.



Float valve with balanced single seat Mod. ATHENA

This valve has been designed to complete the offer of solutions for tank regulation and control, which was restricted to the automatic control valves series XLC 400. Thanks to its exclusive technology ATHENA brings the concept of reliability and performance to the highest standards.



Technical features and benefits

- Body in GJS 500-7 with three ways, allowing the installation both with an angle or a globe pattern, containing an interchangeable sealing seat and piston in stainless steel and a sliding bush in bronze.
- Mobile block composed of the main shaft, obturator, gasket retainer and piston featuring a unique self-cleaning technology (pat. pending) to reduced the accumulation of dirt and maintenance operations.
- The lever mechanism is obtained from a double rod in rolled steel (single rod for DN 50/65) which, by means of stainless steel pivots, puts the shaft in communication with the float which imparts the movement allowing the opening or closing of the valve.
- A large float in stainless steel AISI 304 is connected to the above mentioned rods by means of a stainless steel pipe, onto which it exerts a vertical force.
- Thanks to the balanced single seat the valve will perform with high sensitivity, perfect water tightness even with low pressure values.
- The movements of the obturator during opening and closing are not affected by the incoming water pressure, meaning that transient effects are avoided.

Applications

- Water distribution systems.
- Fire protection storage tanks.
- Irrigation systems.
- Whenever the constant level regulation and control function is required.

Operating principle

Flanged to the incoming pipe, and driven by a large float in stainless steel, the valve automatically controls the water level inside the tank by cutting off the supply whenever it reaches the maximum level and reopens again as soon as it drops.

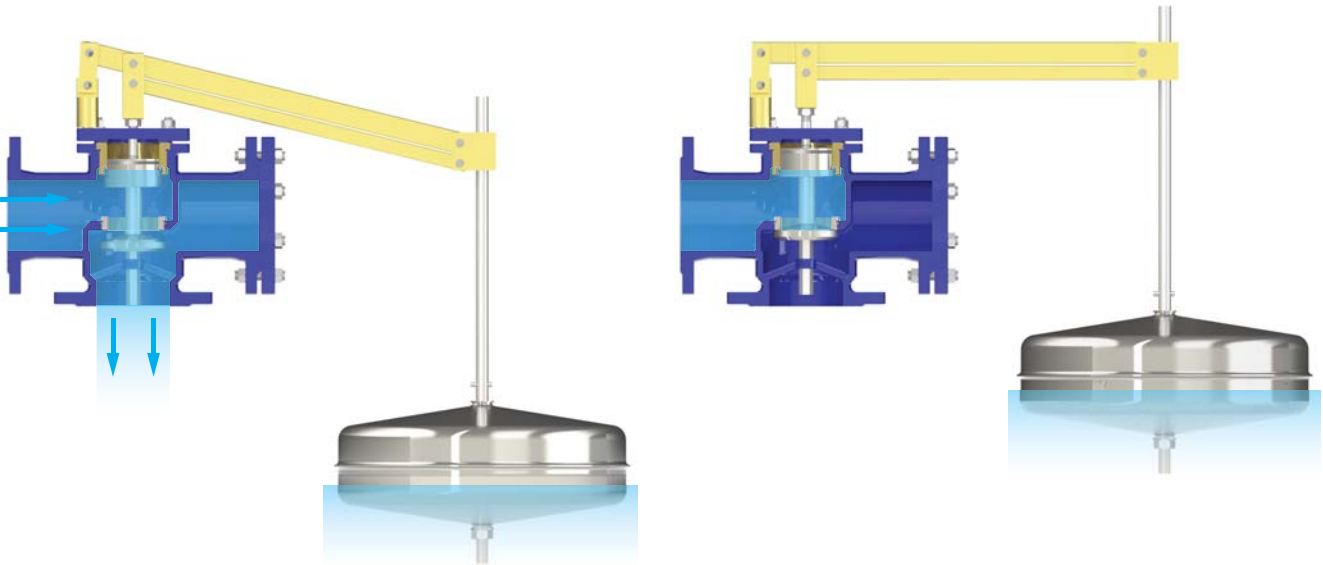

Open valve

As soon as the water level drops inside the tank the lever, to which the float is connected, will push down the mobile block to the open position allowing the water flow through the valve.

Closed valve

When the water level inside the tanks has reached the maximum level the float, thanks to the lever, will move up up the obturator closing the passage through the valve.

Optional



■ **Installation.** Athena has been designed with a three ways body, to allow both the installation as an angle and globe pattern level control valve, simply by placing the blind flange to the desired outlet.



■ **Anti freezing device.** On request the valve is provided with a 3/8" G threaded outlet, which can be used as an anti-freezing device, simply by replacing the tap with a drainage ball valve discharging directly into the tank.

During the winter season, when the temperature drops consistently, the partial opening of the drainage port will create a flow rate inside the valve avoiding frost and possible damages.



■ **Rod rotation.** The rod is normally aligned with the valve axis. It is possible to rotate it on site, with an angle of 45°/90°, to fit the installation requirements.

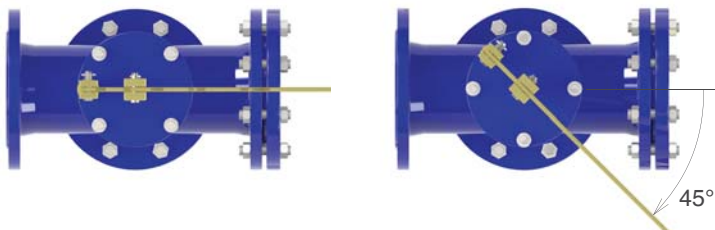

Technical data

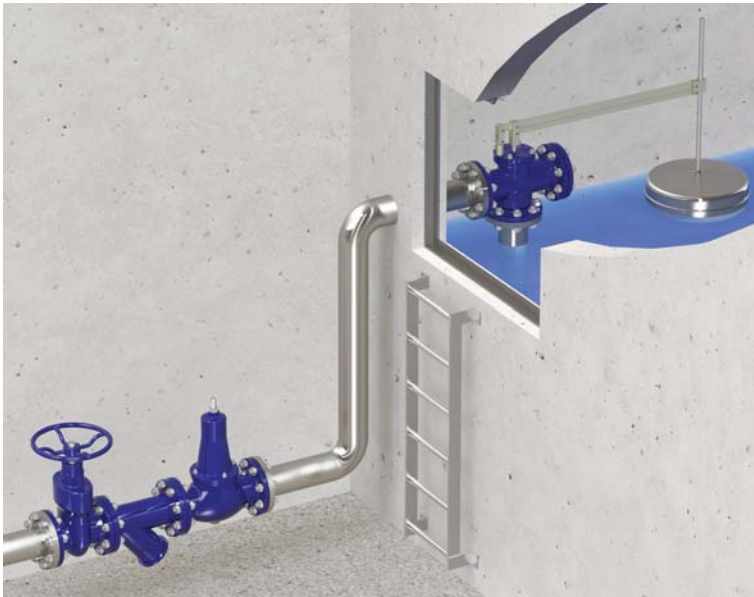

Installation

- Make sure that the supply pipe has the flanges drilled according to the requested PN and that ATHENA is installed in a horizontal position, properly fixed and sustained.
- Gate valves and filters have to be installed to allow for maintenance operations, and to prevent dirt from reaching the internal components of the valve.
- Position the valve in a place which is easy to reach and wide enough for maintenance and control purposes.
- Observe the overflow level and make sure that the outlet flange is always above it, this is to avoid backflow.
- In case of excessive Dp, to avoid cavitation and possible damages to the valve, a direct acting pressure reducing valve CSA VRCD series should be installed.

Working conditions

Max temperature 70°C.
 Max pressure PN 16 (please contact us for higher values).
 To avoid cavitation the Max Dp across the valve should be limited to 8,5 bar for angle pattern, and 6,5 bar for globe pattern installations.

Standard

Designed in compliance with EN-1074/4.
 Flanges according to EN 1092/2.
 Epoxy painting applied through fluidized bed technology blue RAL 5005.
 Changes and variations on the flanges and painting details available on request.

DN mm	40	50	65	80	100	125	150	200	250	300
Kv (m³/h)/bar	21,6	21,6	46,8	68,4	108	155	245	360	648	1008

DN mm	40	50	65	80	100	125	150	200	250	300
Kv (m³/h)/bar	18,4	18,4	39,6	59,4	90	133	209	313	576	864

DN mm	A mm	B mm	C mm	D mm	L mm	H mm	R mm	h mm	Weight Kg
40	230	82,5	173	165	600	Ø220		105	21,0
50	230	82,5	173	165	600			105	21,0
65	290	92,5	193	185	600			180	25,6
80	310	100	212	200	800	200	300	210	32,6
100	350	125	225	220	800	180	400	267	41,0
125	400	125	230	250	800	180	400	267	49,0
150	480	162	351	285	1000	250	400	400	78,5
200	600	183	380	340	1000	250	400	418	118,0
250	730	270	540	405	1220	300	500	510	162,0
300	850	300	610	460	1400	400	500	610	250,0

Head loss coefficient for angle pattern

Kv coefficient representing the flow rate flowing through the valve fully open, and producing a head loss of 1 bar.

Head loss coefficient for globe pattern

Kv coefficient representing the flow rate flowing through the valve fully open, and producing a head loss of 1 bar.

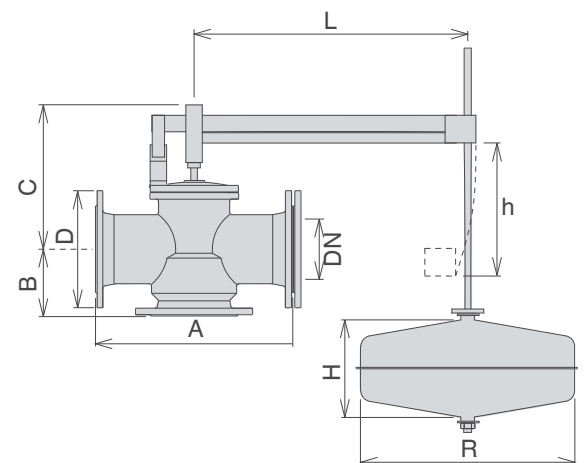

Technical details

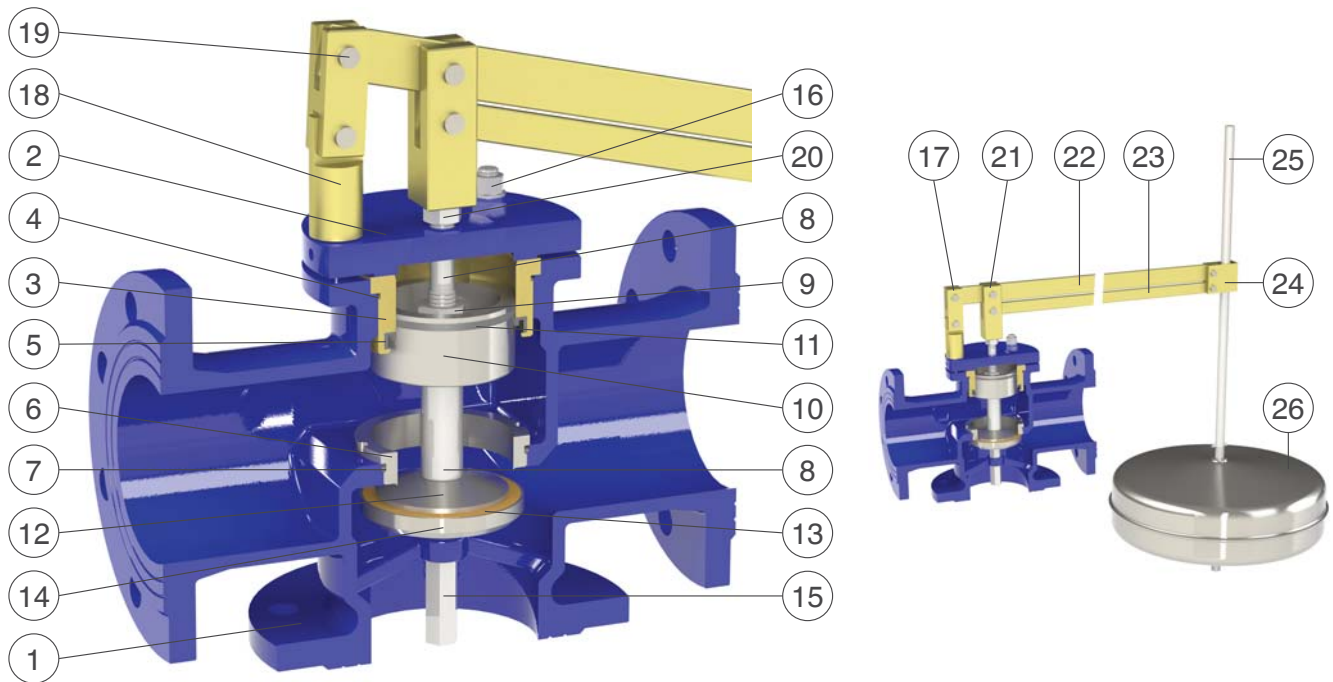

N.	Component	Material	Standard
1	Body	ductile cast iron	GJS 500-7
2	Cap	painted steel/stainless steel	Fe 37/AISI 304/316
3	Guiding bushing	bronze/steel/stainless steel	Fe 37/AISI 304/316
4	O-ring	NBR/EPDM	
5	Lip gasket	NBR/EPDM	
6	Seat	stainless steel	AISI 304/316
7	O-ring	NBR/EPDM	
8	Guiding shaft	stainless steel	AISI 304/316
9	Blocking nut	stainless steel	AISI 304/316
10	Piston	stainless steel	AISI 304/316
11	Guiding ring	PTFE	
12	Counter-seat	stainless steel	AISI 304/316
13	Plane gasket	NBR/Polyurethane	AISI 304/316
14	Obturator	stainless steel	A2/A4/AISI 316
15	Tightening nut	stainless steel	AISI 304/316
16	Studs, nuts and washers	stainless steel	AISI 304/316
17	Upper coupling	steel/stainless steel	Fe 37 double galvanized/AISI 316
18	Lower coupling	steel/stainless steel	Fe 37 double galvanized/AISI 316
19	Pivots	stainless steel	AISI 304
20	Blocking nut	stainless steel	AISI 304/316
21	Shaft pivot	steel/stainless steel	Fe 37 double galvanized/AISI 316
22	Upper lever	steel/stainless steel	Fe 37 double galvanized/AISI 316
23	Lower lever	steel/stainless steel	Fe 37 double galvanized/AISI 316
24	Float coupling	steel/stainless steel	Fe 37 double galvanized/AISI 316
25	Float rod	stainless steel	AISI 304/316
26	Float	stainless steel	AISI 304/316



Float valve with balanced single seat Mod. ATHENA 1"- 1 1/4"

In order to offer a reliable solution for regulation and control of small tanks, CSA has designed the new float valve Mod. ATHENA 1"-1 1/4" PN 16. Thanks to its exclusive technology, with upstream pressure balanced single seat, and the new patented self cleaning piston technology, this valve brings the concept of reliability and performance to the highest standards.



Technical features and benefits

- Body in GJS 500-7 PN 16.
- Cover in brass provided with the self cleaning piston technology driving system.
- Mobile block containing the piston and obturator, both in stainless steel.
- The lever mechanism is made in Fe42 tropicalized or stainless steel and composed of a rod which, thanks to a system of pivots, puts the main shaft in communication with the float allowing the opening or closing of the valve
- Designed for angle pattern installation only and to allow flow conveyance through the outlet.
- Thanks to the balanced single seat the valve will perform with high sensitivity, perfect water tightness even with low pressure values.
- The movements of the obturator during opening and closing are not affected by the incoming water pressure, meaning that transient effects are avoided.
- Pipe (available on request) Ø 76,1X1,5 mm in stainless steel to convey the flow in the tank.

Applications

- Water distribution systems.
- Fire protection storage tanks.
- Irrigation systems.
- Whenever the constant level regulation and control function is required.

Technical details

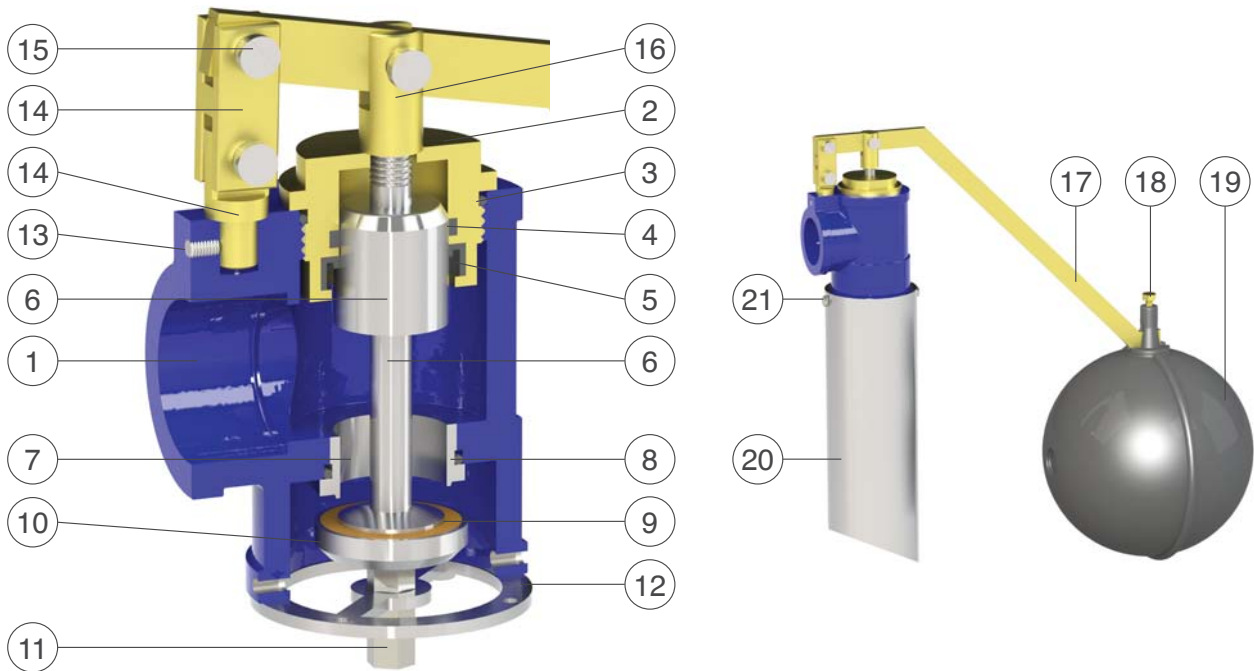

N.	Component	Material	Standard
1	Body	ductile cast iron	GJS 500-7
2	Cap	brass/stainless steel	OT 58/AISI 304/316
3	O-ring	NBR/EPDM	
4	Guiding ring	PTFE	
5	Gasket	NBR/EPDM	
6	Piston	stainless steel	AISI 304/316
7	Seat	stainless steel	AISI 304/316
8	O-ring	NBR/EPDM	
9	Plane gasket	NBR/polyurethane	
10	Obturator	stainless steel	AISI 304/316
11	Tightening nut	stainless steel	AISI 304/316
12	Lower guiding ring	stainless steel	AISI 304/316
13	Plug	stainless steel	A2/A4/AISI 316
14	Upper and lower coupling	steel/stainless steel	Fe 37 double galvanized/AISI 316
15	Pivot	stainless steel	AISI 304
16	Shaft coupling	steel/stainless steel	Fe 37 double galvanized/AISI 316
17	Float lever	steel/stainless steel	Fe 37 double galvanized/AISI 316
18	Screw	steel/stainless steel	Fe 37 double galvanized/AISI 316
19	Float	polyethylene	
20	Conveying pipe (optional)	stainless steel	AISI 304
21	Screws (optional)	stainless steel	A2/A4/AISI 316

Working conditions and head loss

Maximum temperature 70°C.

Maximum pressure PN 16.

To avoid cavitation, max. Δp across the valve should be limited to 8 bar.

The K_v of the valve, meaning the flow rate expressed in m^3/h producing a head loss of 1 bar, is 12,6.

Standard

Designed in compliance with EN-1074/4 .

Threaded connections according to ISO standard.

Epoxy painting applied through fluidized bed technology blue RAL 5005.

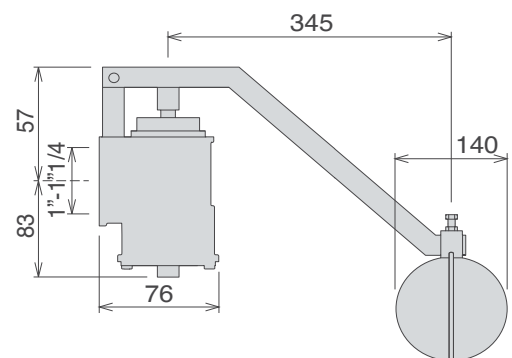



Advanced testing facilities

Designed to reproduce real conditions of modern water distribution systems the CSA testing facility is able to assess the dynamic performances of automatic control valves, direct acting pressure control valves, air valves and anti water hammer valves.

Provided with a high capacity booster pumps station, and linked to an advanced high frequency pressure transducers and flow meters, the testing rig allows for a real time visualization of pressure and flow evolutions. Water hammer events can also be simulated and recorded to prove the efficacy of CSA fast acting relief valve, in addition to level control for which, using an auxiliary stilling tank, a part of the pipeline system is entirely dedicated. The PLC and control station allows for the operation of step by step and solenoid operated valves to determine the sensitivity of such kind of application and pressure management solutions. Thanks to this important and powerful tool valves can be customized, simulated and set according to the project requirements assuring the perfect performance and accuracy.

The testing process

All our valves undergo severe tests according to EN standards to ensure they are mechanically resistant, watertight, and high performing. After testing every valve is identified by means of a metallic tag or sticker, and duly registered and certified.



CSA HYCONSULT

Water hammer analysis CSA Hyconsult

CSA Hyconsult was founded to provide designers and consultants, involved in the design of water distribution and sewage systems, with accurate and unique technical support.

CSA Hyconsult has specialized in hydraulic modelling and transients analysis, entirely through the use of modern computational tools and advanced algorithms. Simulations are essential to predict system responses to events under a wide range of conditions without disrupting the actual system.

Using simulations, problems can be anticipated in possible or existing situations, and solutions can be evaluated in order to invest time, money and material in the most productive manner.

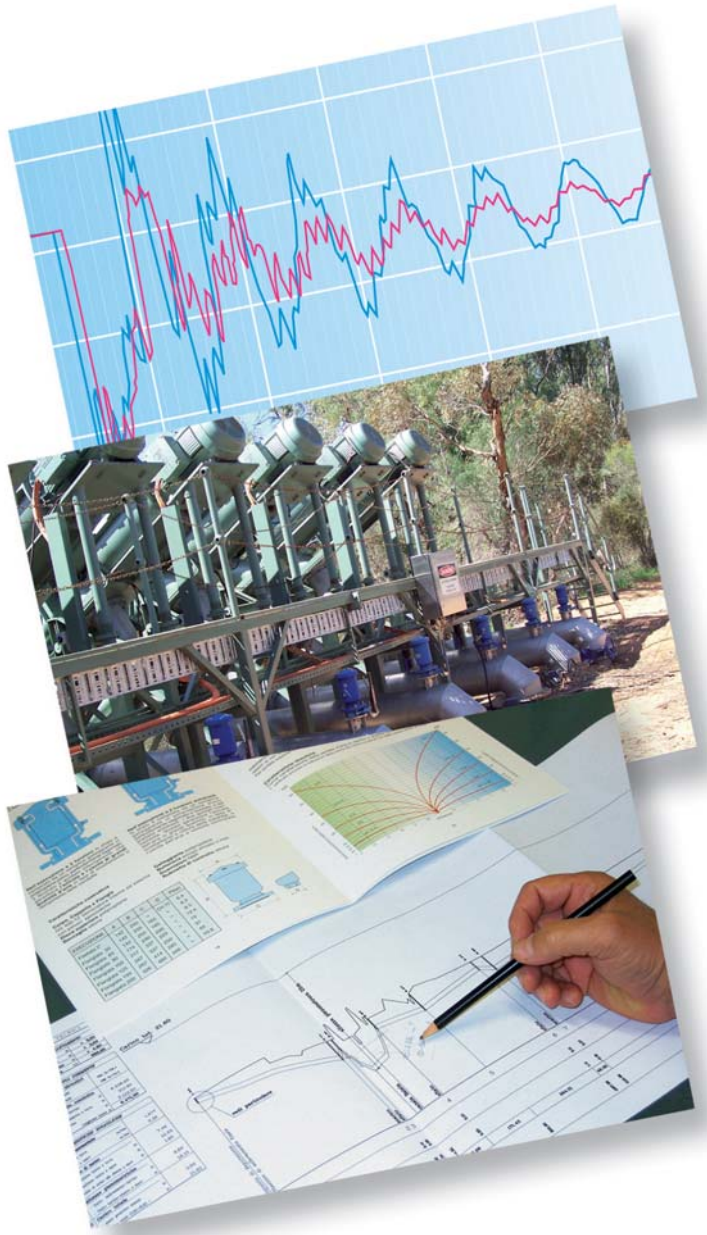

Research and innovation

CSA has always regarded knowledge as being indispensable for the kind of research that consistently feeds innovation at all levels. The R&D department at CSA constantly strives to improve product performance and continually searches for new solutions to meet our customer's needs. Twenty years of experience in valve design and sizing, supported by advanced computational tools, cooperation with external entities at the highest level, and test facilities for the verification of theoretical results which are available for our customers, guarantee our professionalism and reliability.

